

SMARTRACINGTM

PRODUCTS

*A Company Developing Smart Racing
Products Through Engineering*

WEVO Banana Arm EZ Pin
Part No. 552160

Installation Instructions WEVO Banana Arm EZ Pin

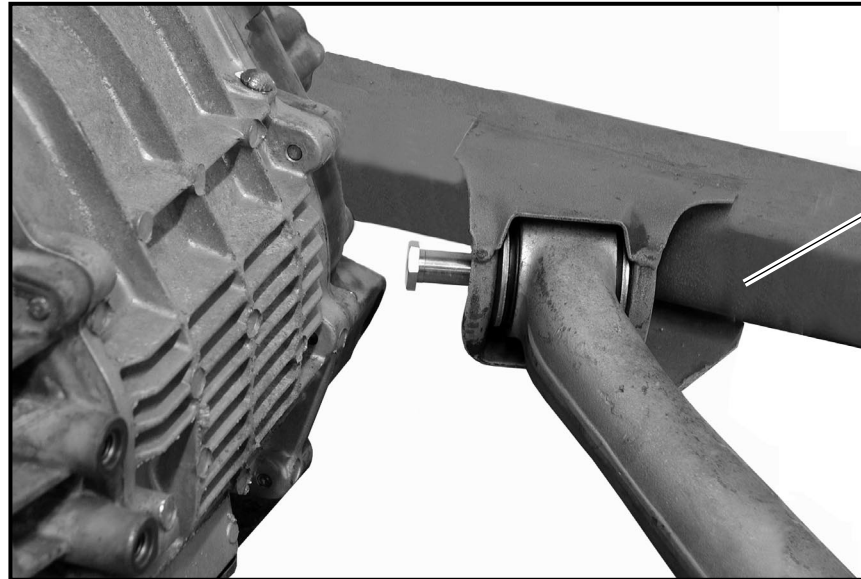

If there is a dimple in this area you may remove the stock bolt and reuse it. You do not need an EZ-pin.

Installation:

- 1) This pin for use in cars that do not have a dimple in the torsion tube.
Note: Cars with a dimple in the torsion tube should use stock bolt.
- 2) Remove stock bolt by cutting it out.
- 3) Remove transmission mount and push transmission to one side.
- 4) Install EZ-pin.
- 5) Push transmission to other side.
- 6) Install other EZ-pin.
- 7) Install transmission mount and tighten.
- 8) Tighten EZ-pin to 38 ft pounds using blue Locktite.
- 9) Check that the EZ-pin bolt has clamped tight on the banana arm and that there is no sideways motion to the banana arm.
(Prying with a screw driver or pry bar works well for checking this.)

Questions or comments please call 408.369.9997 or FAX 408.369.9741
www.smartracingproducts.com