

SMARTRACING™ **PRODUCTS**

*A Company Developing Smart Racing
Products Through Engineering*

Camberball/Weltmeister Camber Strut Modification

Top View

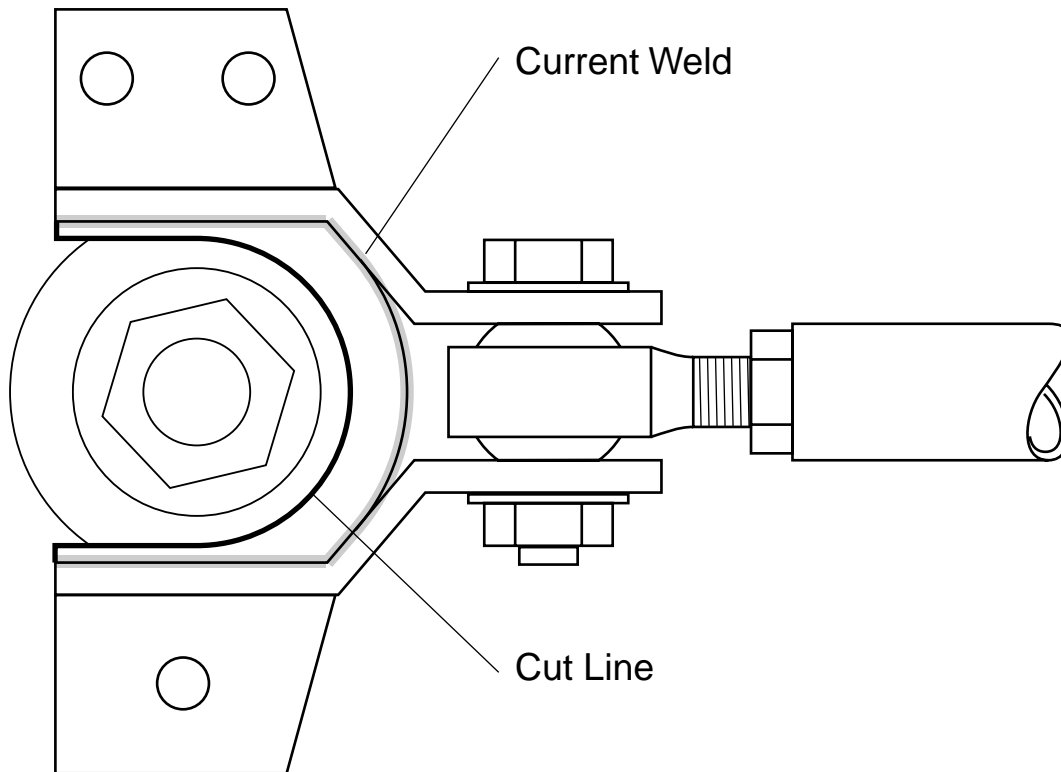

Notes

1. Goal is to allow installation of SRP camberball and still use the Weltmeister strut tower truss.
2. Cut as shown and debur edges.
3. Once complete, both assemblies will move together when camber or caster adjustments are made.

Questions or comments please call 408.369.9997 or FAX 408.369.9741
www.smartracingproducts.com