

SMARTRACING™

PRODUCTS

A Company Developing Smart Racing
Products Through Engineering

WEVO GateShift Kit for 915 Transmissions
Part No. 332100

WEVO GateShift Kit for 915 Transmissions

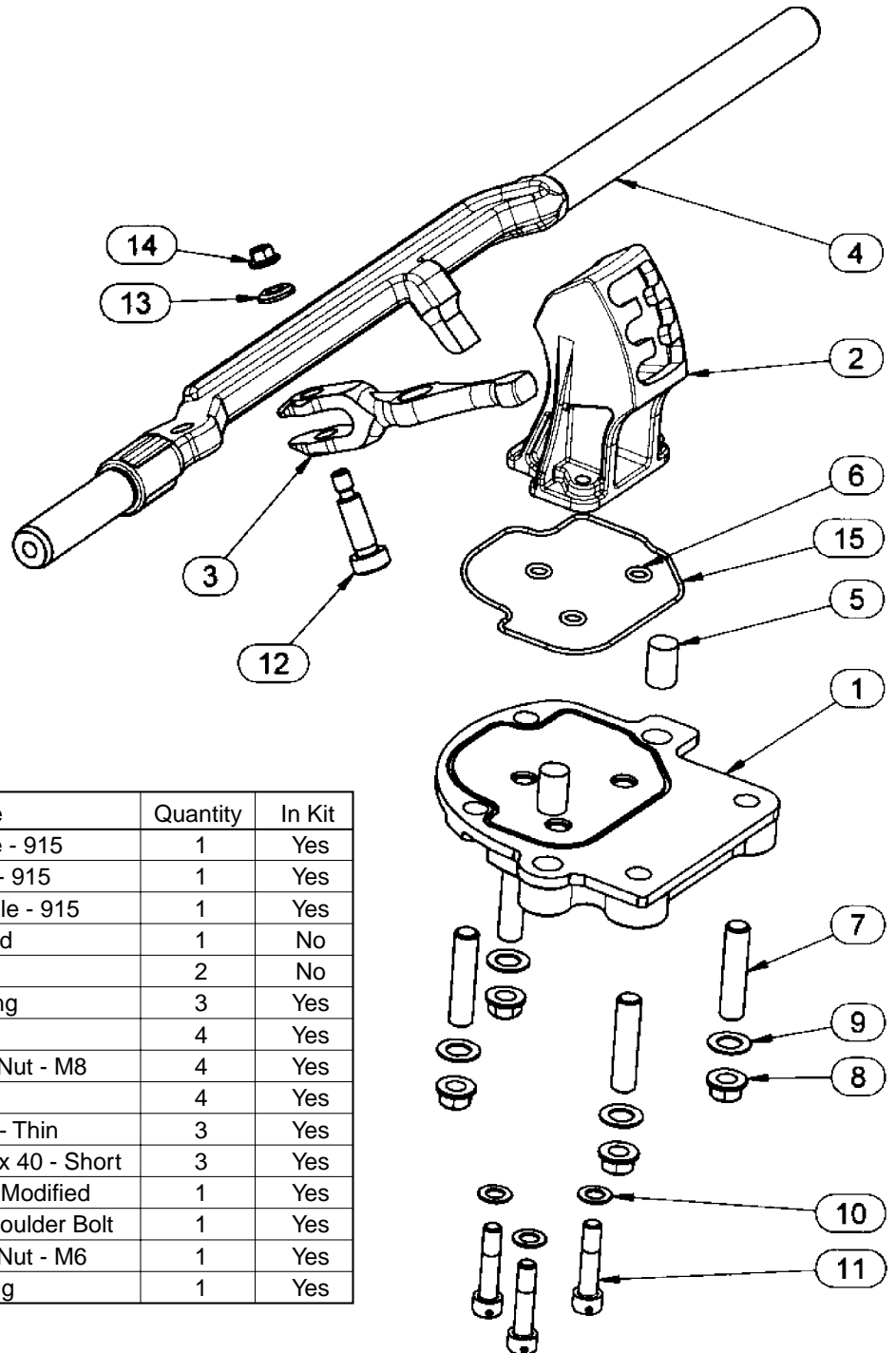

Item	SRP Part No.	Part Name	Quantity	In Kit
1	332101	Bottom Cover Plate - 915	1	Yes
2	332102	Gate Shift Casting - 915	1	Yes
3	332103	Gate Shift Kit Dongle - 915	1	Yes
4	332104	Main Gear Shift Rod	1	No
5	332105	Dowel Pin 10mm	2	No
6	332106	Gate Casting O-Ring	3	Yes
7	332107	Stud - M8 x 35	4	Yes
8	332108	K-nut Self Locking Nut - M8	4	Yes
9	332109	Washer M8	4	Yes
10	332110	M6 Spring Washer - Thin	3	Yes
11	332111	Cap Head Bolt M6 x 40 - Short	3	Yes
12	332112	Shoulder Bolt M8 - Modified	1	Yes
13	332113	Fit Washer - M8 Shoulder Bolt	1	Yes
14	332114	K-nut Self Locking Nut - M6	1	Yes
15	332115	Bottom Cover O-ring	1	Yes

Questions or comments please call 408.369.9997 or FAX 408.369.9741
www.smartracingproducts.com

332100.ILL Rev 1

WEVO GateShift kit

This kit includes all the parts required to install the WEVO GateShift kit. The kit will improve accuracy of gear selection and protect the internals of a 915 transmission from the extraneous gear selection forces that can damage parts, adjust internal set-up and reduce the life of transmission components.

The gate design gives a very positive feedback to the driver and assists with accurate “hand mapping” of the lever position that selects each gear. This kit can help protect your 915 transmission from problems that might accelerate the need for future overhauls.

Installation of this kit will take approximately 2 hours for a technician who is familiar with the Porsche 915 transmission and has the unopened 915 transmission sitting on the bench. If the installation is performed concurrent with a transmission overhaul, the installation adds only minutes to the assembly of the 915 transmission. This is not a difficult kit to install and can be performed by a confident home mechanic who has the correct tools.

This kit can not improve any gear selection condition related to worn or damaged synchromesh components.

This kit can be used with any stock or aftermarket short-shifter handpiece that does not use a gate device on the lever. The user should establish the effectiveness and correct adjustment of any reverse lock-out mechanism. The WEVO GateShift kit does not have any mechanical reverse lock-out device, although the tolerance of the gate design makes selection of reverse gear very difficult except when intentional.

This kit will function correctly when the geometry of the shift rail parts is arranged as shown in the official Porsche workshop manuals. If you refer to the Workshop Manual 911 Volume IV from Model on 72 Assembly Group 3, section 3.1-2/1, the instructions and diagrams in these pages will allow for checking of original factory geometry.

Do not attempt to use the WEVO GateShift kit until the original factory geometry has been verified. This is a simple procedure, which will not take longer than 30 minutes. Adjustments are very simple, requiring no special tools. Any technician who is confident to install this kit will find no difficulty in adjusting the shift rails if required.

Before you start, be sure to thoroughly clean the exterior of the transmission. We recommend working with the transmission vertical - standing of the bellhousing face (beware to protect the nose of the input shaft)

Tools / Equipment required

7mm box / open end wrench
13mm box / open end wrench
10mm socket
13mm socket
27mm socket
36mm socket
4mm hex key
5mm hex key socket
Torque wrench <35 Nm range
Torque wrench <260 Nm range
3.5mm 0 pin punch
5mm 0 blunt nose punch
6 mm 0 pin punch
Soft hammer
Steel hammer
Hot air gun or propane torch
Needle nose pliers
Lockwire pliers
Loctite 262 (or other permanent stud lock adhesive)
Hylomar HPF (or other non-setting sealant)
Safety razor blade
Synthetic grease

Procedure

Use the exploded diagram and refer to parts by the ITEM # also used for identification in this text.

1. Remove the front cover - beware to recover the reverse switch pin (4mm 0 x 52mm) that will fall out of the switch body as the front cover is removed.
2. Remove the front cover gasket and discard - your kit includes a replacement gasket.
3. Remove the cross pin from the input shaft, select 2nd gear and 5th gear by moving the 1st/2nd shift rail and the 5th /Rev shift rail which are the two shift rails lowest in the transmission. This will prevent the shafts from turning and allow the input shaft and pinion shaft nuts to be loosened.
4. Undo the main nut on both the input shaft and the pinion shaft.
5. Remove all the 5th and reverse gear assemblies inside the front cover, there is a logical sequence which is obvious as you commence this task. There are no retaining rings or pins that can prevent these gears from sliding off the shafts. You might need to use light force to get the slider hub moving on the pinion shaft.
6. Remove the bottom cover plate - discard the gasket - your kit includes an "O"-ring seal for this purpose.

7. Remove the maincase nuts and carefully lift the maincase off the shafts. The main shift rod (4) must also come away with the casting and this should be lifted carefully to avoid damaging the gasket surface of the final drive housing. Make a note of the orientation of the main shift rod inside the maincase; this will be needed later in assembly.
8. Remove and discard the gasket from between the maincase and the final drive housing - your kit includes a replacement gasket.
9. Remove the 4 studs that fasten the original bottom cover plate. Carefully clean this whole mounting surface - an "O"-ring will make a critical seal onto this surface, so take time to detail any imperfections. Use Loctite 262 or another permanent stud lock adhesive to install the four M8 x 35mm studs (7) into these positions. The studs should bottom into the threaded holes in the maincase and protrude by 16 - 17 mm.
10. Use a punch or press to drive the clevis pin from the original dongle on the main shift rod - discard the cotter pin - your kit includes a replacement pin.
11. Thoroughly clean the shift rod in the area where the dongle pivots - there is often glazing from old oil in this area. Scotchbrite the parts including the clevis pin bore through the shift rod.
12. Polish the clevis pin if this is going to be re-used. (see 13 Alternate) Ensure it is clean and free from burrs that might have been created during removal.
13. Prepare the new dongle (3) for installation - check that the clevis pin is an easy push fit through the dongle. If this pin is tight - check for burrs and repolish the clevis pin with 1000 grade wet-o-dry to de-glaze the surface.

ALTERNATE

The June 2003> kits are now delivered with parts 12, 13 & 14 which replace the original clevis pin and cotter pin. The ground shoulder bolt (12), fit washer (13) and K-nut (14) allow for easier assembly of the Dongle (3) onto the Main Shift Rod (4). This also allows for removal of the Gate casting (2) with the transmission fully assembled - if ever required.

14. **ONLY APPLICABLE IF USING THE ORIGINAL CLEVIS PIN.** When the pin fit is correct, use a hot air gun or cool butane torch to warm the section of the shift rod where the pin is installed - the pin has a light interference fit through this bore and heating the rod will ease this fit. Avoid overheating - there should be no change of color.
15. Fit the clevis pin from the top side of the main shift rod as installed in the car - you should have noted which is the top side earlier. Do not drive the clevis pin all the way through the dongle - this will bind the head of the clevis pin and the dongle. The clevis pin is correctly installed when the cotter pin can be fitted and the dongle is free to pivot on the clevis pin (pin will be stationary in the main shift rod). You can use either the clevis pin or the shoulder bolt (12) alternative as below.

ALTERNATE June 2003>

The ground shoulder bolt (12) is a transition fit through the main shift rod (4). This means no heating will be required, the bolt will slide through at room temperature. The shoulder bolt (12) should be installed per the exploded diagram - with the bolt head facing the bottom cover. The fit washer (13) is arranged with the beveled edge facing the nut, the M6 K-nut (14) should be torqued to 13 Nm.

16. Fit the main shift rod (4) back into the maincase - so that it is situated in the same way as during removal. Take the gate casting (2) and fit this onto the dongle (3) so that it is hanging in the 5th gear slot. The casting must be arranged partially out of the hole for the bottom cover to allow it to pass over the gear cluster as the maincase is lowered back into position.
17. Take a couple of dry runs at this, holding the parts in the right place and getting the main shift rod back into the bore in the final drive housing can be awkward. It is easy to tear the new gaskets or damage the gasket surface on the final drive housing - so be prepared to practice a couple of times.
18. When you are comfortable with the assembly procedure, prepare gasket surfaces with a non-setting sealing compound such as Hylomar HPF.
19. Fit the gasket and replace the maincase with the gate casting included.
20. The two 10mm Ø dowels (5) from your original bottom cover need to be salvaged to prepare the new bottom cover. Use a hot air gun or cool propane torch to warm the cover in the area of the dowels. These dowels can easily be extracted with pliers or Vise-Grip's. Polish the dowels to remove any burrs created when extracting the dowels, then push the dowels into the new bottom cover (1) with Loctite 262 or similar stud lock adhesive. (Note - if you burr the dowels during removal - push the damaged surfaces into the cover)
21. The new bottom cover needs to have the large "O"-ring (15) installed in the irregular shaped groove. Use a non-setting sealing compound as above to retain the "O"-ring in the groove. Check that you have the three M6 cap head bolts (11), three M6 spring washers (10) and 3 small "O"-rings (6) ready. Place the spring washer onto each M6 bolt. Add a small amount of sealing compound to the plain shank of the bolts and push the bolts through the holes. Fit a small "O"-ring (6) onto each bolt and ensure that the "O"-ring seats in the groove.
22. Ensure that both shift rails are in neutral. Offer the bottom cover up to the maincase. Before the bottom cover is engaged on the M8 studs, you will need to start the three M6 bolts into the base of the gate casting. The gate casting is highly mobile while it is hanging on the dongle - familiarize yourself with where the gate casting can rest while you start the bolts. Tighten the M6 cap head bolts (11) until they are just snug. The cover can now be fitted up to the maincase surface, with all parts correctly arranged, the only resistance you will feel is the final clamping of the large "O"-ring, the dongle should move freely in the gate casting.
23. Replace the ten M8 nuts around the joint between the maincase and the final drive housing - new hardware is included in the kit.

24. Re-assemble the 5th and reverse gear components and install both the pinion shaft and the input shaft nuts finger tight.
25. You should now be able to test the operation of the shift gate casting by selecting all the gears. Once you are satisfied at the smooth operation of the dongle in the gate casting you must torque the shaft nuts to the original torque settings.

Input Shaft 120 - 140 Nm
Pinion Shaft 240 - 260 Nm
26. Install the roll pin through the input shaft and punch the rim of the nut into the pinion shaft to complete this task.
27. Clean the gasket surface of the front cover and matching face on maincase, prepare with non-setting sealant as above and fit the paper gasket. Fit the reverse switch pin into the reverse switch and retain with a small dab of grease.
28. Fit the front cover and replace the nine M8 nuts - new hardware is included in the kit.
29. Tighten the nineteen M8 nyloc nuts that join the gear casings - torque to the original setting of 22 - 25 Nm.
30. Tighten the four M8 K-nuts (8) on the bottom cover to 30 - 32 Nm.
31. Tighten the three M6 Cap head bolts (11) that fasten the gate casting to the bottom cover. Torque to 16 - 18 Nm. Lock wire the three M6 bolts together in a conventional lock wire pattern. (Lock wire included in kit)

The installation of the WEVO GateShift kit is now complete.

OTHER WEVO PRODUCTS FOR YOUR 915 TRANSMISSION

The installation of a WEVO PSJ - Precision Shift Joint is highly recommended. Follow the instructions for the PSJ to achieve the correct set-up of the shifter handpiece if that part is installed. Use either the WEVO Racing PSJ (SRP No. 733105) or the WEVO Stock 911 PSJ (SRP No. 733101), either will offer a significant improvement in shift linkage precision.

The WEVO 915 shifter (732150 silver, 732151 black, or 732153 classic) will also improve your gear selection precision, our shifter is the most compatible shifter handpiece to use with the WEVO GateShift kit.

Use the original instructions for set-up of all other shifter mechanisms.

Your WEVO GateShift kit will offer the best performance when all the components of your gear shift assembly from handpiece to transmission are restored to new or improved condition.