

**SMARTRACING**  
PRODUCTS

**FOX**  
RACING SHOX

Our Fox Shocks are now Available!

- Our best performing shock now available for your 1969-89 911 and 914.
- Externally adjustable canister pressure and bump.
- Adjustable front spindle heights.
- See article in the August 2003 issue of Excellence magazine. See it on our web site.



**Front Shock and Spindle**

**\$997.00 each 911/914**

- Left Kit ..... 413351  
Right kit ..... 413352

**Rear Shock**

**\$465.00 each**

- 911/914 Rear shock kit ..... 513351  
914 Rear mounting kit .. \$121.26 .. 513570

**Pressure Gauge**

**\$67.06**

- Gauge ..... 414200



Adjustable front spindle height



# Smart Racing Products Anti-Roll Bars

- Four bar sizes 20, 23, 27, & 31 with overlapping bar rates.
- All metric hardware
- Interchangeable front to rear.
- All use the same hardware.
- High quality, very adjustable
- Links won't bind
- Correct kinematics

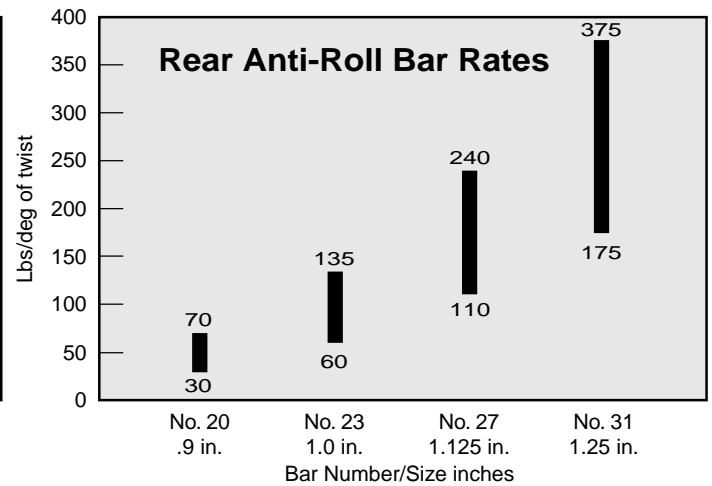
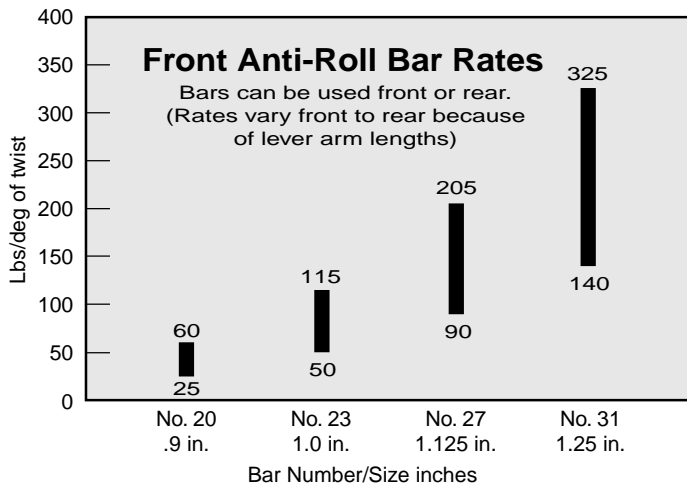
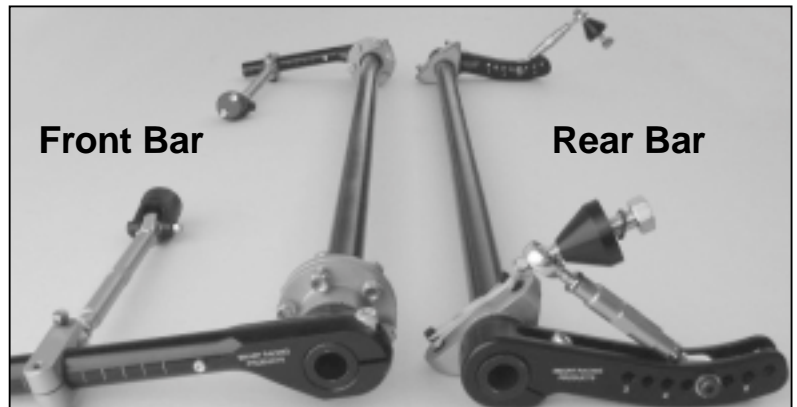

**Complete Front and Rear Kit**  
**\$1,486.00**

BAR RECOMMENDATIONS		
911 1969-1971	Front	Rear
Street	20	20
Street/Track	20	20
Track	27	27
GT	27	27
911 1972-89	Front	Rear
Street	20	20
Street/Track	23	23
Track	31	27
GT	27	27
930 1972-89	Front	Rear
Street	20	20
Street/Track	23	23
Track	27	27
GT	23	27

**Front Kit**

- (includes one bar) . . . . \$822.50
- Stock control arm . . . . . 431010
- ERP control arm . . . . . 431020

**Rear Kit**

- (includes one bar) . . . . \$663.50
- Early mount 1969-1977 . . 531010
- Late mount 1978-1989 . . 531020

**Individual Bars \$190.50 each**

- No. 20 bar . . . . . 431110
- No. 23 bar . . . . . 431120
- No. 27 bar . . . . . 431130
- No. 31 bar . . . . . 431140

**Turning Radius Limiter**

Cars with larger tires may have a problem with wheel well and caliper clearance. Using our steering rack limiters will limit the turning radius so there is tire and caliper clearance. Two per car required.

- 476100 29mm shaft . . . . . \$30.00 ea.
- 476120 30mm shaft . . . . . \$31.00 ea.



**WEVO 911 Rear Anti-Roll Bar Mounts**

A permanent solution to the problem of broken rear anti-roll mounts on the 911 chassis. The WEVO Console is a sturdy, investment cast, heat treated alloy steel replacement part. Use this super duty console to replace cracked, torn or missing rear anti-roll bar mounts on any 911.  
**533015 . . . . . \$89.75 ea.**

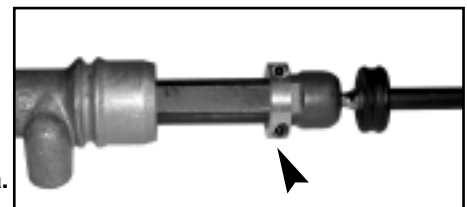

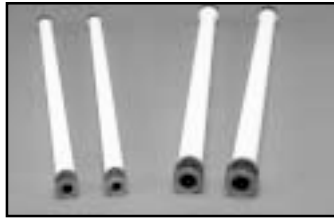

**Tubular vs. Solid Torsion Bars**

The controversy rages on, but the reality is that the real benefit is lightness, not that they are "faster acting". If you have a very light car - say less than 1900# and you are trying to get every ounce out of the car and you can not use coil overs, buy the tubular bars.

**Sway-Away Solid Torsion Bars**

**Priced as sets**

Front 911/912/930 65-89, 914-6		
21mm .....	<b>421100</b>	<b>\$259.50</b>
22mm .....	<b>421110</b>	<b>\$259.50</b>
23mm .....	<b>421120</b>	<b>\$259.50</b>
Rear 911 65-86; 930 76-88 4-speed		
26mm .....	<b>521100</b>	<b>\$274.60</b>
27mm .....	<b>521110</b>	<b>\$274.60</b>
28mm .....	<b>521120</b>	<b>\$274.60</b>
29mm .....	<b>521130</b>	<b>\$274.60</b>
30mm .....	<b>521140</b>	<b>\$274.60</b>

**Sander Tubular Torsion Bars**

**Priced each**

Front 911/912/930 65-89, 914-6		
21mm .....	<b>421260</b>	<b>\$175.25</b>
22mm .....	<b>421261</b>	<b>\$175.25</b>
23mm .....	<b>421262</b>	<b>\$175.25</b>
24mm .....	<b>421263</b>	<b>\$175.25</b>
Rear 911 65-86; 930 76-88 4-speed		
26mm .....	<b>521350</b>	<b>\$197.00</b>
27mm .....	<b>521351</b>	<b>\$197.00</b>
28mm .....	<b>521352</b>	<b>\$197.00</b>
29mm .....	<b>521353</b>	<b>\$197.00</b>
30mm .....	<b>521354</b>	<b>\$197.00</b>
31mm .....	<b>521355</b>	<b>\$197.00</b>
33mm .....	<b>521356</b>	<b>\$197.00</b>
Rear 911 87-89; 930 1989 5-speed		
28mm .....	<b>521357</b>	<b>\$197.00</b>
29mm .....	<b>521358</b>	<b>\$197.00</b>
30mm .....	<b>521359</b>	<b>\$197.00</b>
31mm .....	<b>521360</b>	<b>\$197.00</b>



**Rear Control Arm Pivot Boxes (911SC to 911 Chassis), (930 to 911 Chassis), or (930 to 930 Chassis)**

We have two styles of pivot boxes to choose from; both allow the adjustment of camber from inside the car while not effecting toe settings. One converts non-turbo cars to accept 930 rear control arms. The other provides the same advantages of adjustability with the stock 911 control arms. Allows easy at-track camber and roll center adjustments. Dramatically improves rear suspension geometry to decrease squat tendencies. Easily accommodates very low ride heights. Also allows for bump steer adjustments on lowered cars. Self-jiggling for easy and accurate installation. Race proven on IMSA, SCCA and PCA Club Racing cars. Requires competent welding and basic fabricating skills and the additional clearance in the factory jump seat area. Comes complete with detailed instructions.

911SC arms to 911 chassis ..... **562010** ..... **\$590.00 kit**  
 930 arms to 911 chassis ..... **562020** ..... **\$590.00 kit**  
 930 arms to 930 chassis ..... **562010** ..... **\$590.00 kit**



**Rear Monoball Kit**

Fits 1965-1989 911's. These cartridges replace the factory rubber inner control arm bushings, which allows the arm to move fore and aft affecting toe settings. The monoball in the cartridge is very strong and very positive. Toe and camber settings are a breeze because the monoball is nearly frictionless and doesn't fight more extreme settings the way the factory and certainly aftermarket bushings do.

**552101** ..... **\$228.00 kit**

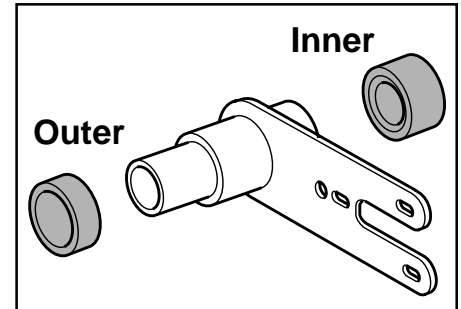

**Suspension Bushing Kits**

All of our bushing have to be custom fitted to each car. An instruction kit on how to do that is included with every bushing you buy from us as well as available from our website. **Do not install these bushings without reading the instructions carefully and completely.**

Inner 911 65-68 .... **551200** .. **\$15.00 ea.**  
 Inner 911 69-76.5 .. **551220** .. **\$15.00 ea.**  
 Inner 911 76.5-89 .. **551210** .. **\$18.00 ea.**  
 Outer 911 65-89 .... **551220** .. **\$15.00 ea.**



**WEVO Banana Arm EZ Pin for 1972 911's**

These pins replace the factory bolts and allow replacement of the bolt without removing engine and transmission from 1972 cars and cars that do not have a dimple in the torque tube. All other cars should use the stock bolt.

**552160 (2 per car)** ..... **\$99.65 kit**

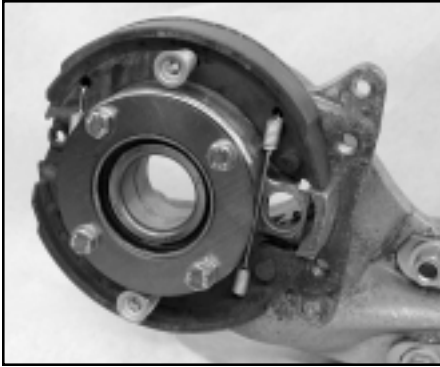

**911 Rear Axle Bearing Retainer for Aluminum Banana Arms**

Holds the bearing more firmly than the weak factory stamped steel plate. The retainer is very stiff and won't allow the bearing to "rock" in the control arm bearing bore. This is a common misconception - that the bearings are bad but in reality the bore may be becoming egg shaped and the retainer plate can no longer support the bearing correctly.

**542110 ..... \$73.76 kit**

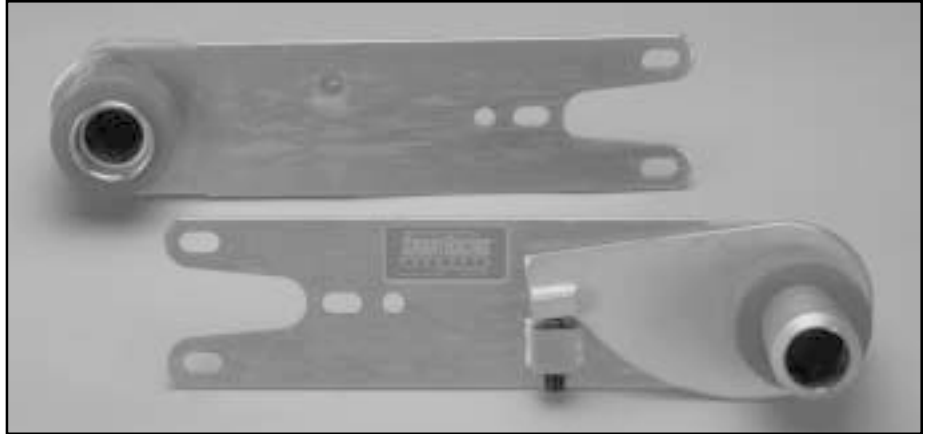

**Adjustable Rear Spring Plates**

These spring plates have been around for over 20 years because they work so well. They are strong and easily adjustable. If you are serious about setting the ride heights and corner weights correctly, these will make the job orders of magnitudes easier. Make sure you put some anti-seize compound on the adjusting screw when installing them.

911 '69-86, 911 Turbo '76-88 .....	<b>561100</b> .....	<b>\$380.55 kit</b>
911 '65-68 .....	<b>561110</b> .....	<b>\$380.55 kit</b>
911 '87-89, 930 '89 .....	<b>561120</b> .....	<b>\$380.55 kit</b>



**Rear Coil Over Hardware Kit for Bilstein RSR Shocks**

Kit includes all the parts necessary to install coil over springs to a Bilstein RSR rear shock.

**523110 ..... \$187.20 kit**



**ERP 935 Rear Spring Plates**

Replace the factory spring plates when the cars are converted to coil over rear suspension. This kit is ideal in that it is adaptable for several installation configurations. Camber angles are set conventionally using the factory concentric, but toe angles are set from the side of the car instead of under it. Camber and toe settings do not influence one another any more!

**561200 ..... \$892.30 kit**

# 5 Rear Axle 911 1969-1989

# SMARTRACING PRODUCTS

511004	Rear Bilstein Bump Rubber	9.00	542105	Wheel Bearing 930 Sleeve -89	102.55
511004.1	Bilstein rear shock nut, top (M10x1.0)	1.77	542106	Wheel Bearing 930 Inner Seal -89	22.10
511005	RSR Rear Shock Bearing	18.95	542107	Wheel Bearing 930 Seal Outer -89	23.00
511006	RSR Rear Shock Clip	0.50	551100	Rear spring plate bushing set for factory spring plates	59.90
511007	RSR Rear Shock Bushing	8.20	551110	Rear Spring Plate Bushing Set for Factory Spring Plates to '76.5	51.43
511008	911 Bilstein Rear Shock 73-89 with Sport Valving	128.16	551120	Rear Spring Plate Bushing Pack for '76.5 and later 911's	57.14
511011	911/930 Bilstein Rear Shock '73-89, HD, each	127.25	551130	Outer Adjustable Spring Plate Bushing 65-89	6.00
511012	911 Bilstein Rear Shock '68-72, Sport, each	137.10	551140	Inner Adjustable Spring Plate Bushing 65-68	6.00
511013	911 Bilstein rear shock absorbers 68-72, HD, each	145.00	551150	Inner Adjustable Spring Plate Bushing 69-89	6.00
511016	911 Bilstein Rear Core Shock -89..(Return for credit of \$75.00)	100.00	551160	Polybronze Adj. Spring Plate Bearings, 65-89 911/912/930, set of 4	295.00
511200	911 Bilstein RSR Rear Shock 72-89	376.60	551230	Ring for Rear Spring Plate Bushing Inner 911 76.5-89	1.10
521501	911 Rear Coil Over 8" x 2.25" x XXX#	79.95	551250	Neatrix 911 Rear Spring Plate Bushings, set of 4	64.98
521502	930 Rear Coil Over Springs 8" x 2.25" x 600#	79.95	551270	Factory Inner Control Arm Bushing 911/930/912, need 4	41.25
522101	911 Rear Coil Over 9" x 2.25" x XXX#	79.95	551280	Inner Control Arm Bushing 911/930/912	14.75
523100	Rear (Tall) Upper Hat (each)	100.00	551300	Sway Bar Bushing for Factory Bar Rear 911 65-77 16mm	11.50
523112	911 69-89 rear upper shock clevis for monoball shock top mounting.	220.00	551310	Sway Bar Bushing for Factory Bar Rear 911 65-77 19mm	11.50
532110	Shakle for rear ARB (left side)	18.40	551320	Sway Bar Bushing for Factory Bar Rear 911 65-77 22mm	11.50
532120	Shakle for rear ARB (right rear)	18.40	551330	Sway Bar Bushing for Factory Bar Rear 911 78-89 18mm	15.00
532130	Bushing cup for ARB (rear)	3.00	562110	Bolt for Rear Pivot Boxes	4.82
533011	SRP ARB Bracket Doubler	15.00	562120	Washer for Rear Pivot Boxes	0.38
533012	SRP ARB Bracket Nut	3.65	562130	Nut for Rear Pivot Boxes	1.82
533014	Mounting console for rear anti-roll bar...Fits 78-89, use Bow Retainer 113.411.333 to use with...	75.97	563103	930 Rear Aluminum Control Arm Left	1,739.14
542096	911 -'68 Rear Wheel Bearing Outer, 2 per car.	26.15	563104	930 Rear Aluminum Control Arm Right	1,739.14
542097	911 -'68 Rear Wheel Bearing Inner, 2 per car.	76.92	563105	930 Control Arm Hub, 2 per car	559.76
542098	911 -'68 Rear Wheel Bearing Seal Inner, 2 per car.	37.58	563106	930 Control Arm Drive Flange, 2 per car	542.13
542099	911 -'68 Rear Wheel Bearing Seal Outer, 2 per car.	6.15	563107	930 Control Arm Nut, 2 per car	17.44
542100	911 Rear Wheel Bearing, '74 - '89	41.40	563108	930 Control Arm Washer, 2 per car.	7.66
542101	911 Rear Wheel Bearing '69-73	41.53	563109	930 Control Arm Cotter Key, 2 per car.	0.40
542103	Wheel Bearing 930 Inner -89	22.95			
542104	Wheel Bearing 930 Outer -89	30.35			



**ERP C2 Rear Spring Plate**

As with our ERP 935 spring plates for the '89 and earlier cars, these 964 spring plates are stronger, have a greater range of adjustability and more positive control of suspension settings because of the spherical rod end. Quality is unmatched.  
**561210 (2 per car) ..... \$375.00 ea.**

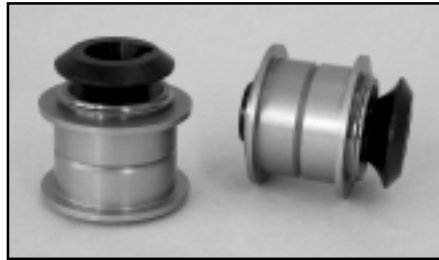

**ERP C2 Rear Monoball**

Outer 964 rear control arm monoball takes all of the factory rubber out and replaces it with a strong and positive monoball. Bolts right in and works best when used with the inner monoball kit (part number 561210) and the springs plates listed above.  
**552210 ..... \$607.69 kit**



**ERP 964/993 Shock Monoball**

Replaces the factory rubber mount system with a positive monoball for the upper rear anchor of 964/993's.  
 964 .... **552509 (2 per car) . \$207.69 ea.**  
 993 .... **552510 (2 per car) \$207.69 ea.**



**MODE 964/993 Shock Monoball**

Replaces the factory rubber mount system with a positive monoball for the upper rear anchor of 964/993's. Can only be used with Bilstein or JRZ Cup style rear shocks.  
 964 89-90 ..... **552507 ..... \$517.00 kit**  
 964 91-94 ..... **552508 ..... \$581.50 kit**  
 993 95-98 ..... **552512 ..... \$581.50 kit**

511020	964 Bilstein Rear Shock C2/4/T 89-90	165.95	532110	Shakle for rear ARB (left side)	18.40
511022	964 Bilstein Rear Shock C2/4/T 91-94	165.95	532120	Shakle for rear ARB (right rear)	18.40
511202	964 Bilstein Cup Rear Shock 89-94	531.20	532130	Bushing cup for ARB (rear)	3.00
521503	964 Rear Sport+ Spring, 89-94....NOT AVAILABLE	0.00	533011	SRP ARB Bracket Doubler	15.00
521504	964 Competition Rear Spring - 600	79.95	533012	SRP ARB Bracket Nut	3.65
521505	964 GT Rear Spring - 700, car <2400 lbs	79.95	534101	964 Euro RS Rear Sway Bar, 89-94 C2/4, 18mm, 3 Adj., needs (2) 534104, uses stock drop...	234.83
521506	964 GT Rear Spring - 700#, car >2400 lbs	69.98	534102	964 RS/Euro RS Rear Sway Bar Drop Link, 89-94 C2/4, Left	91.42
521507	964 GT Rear Tender Spring - 200, 2 per car, also need (2) 422132	84.98	534103	964 RS/Euro RS Rear Sway Bar Drop Link, 89-94 C2/4, Right.	91.42
521508	ERP 964/993 Spring Hat 12mm Hole, 2.25" Spring, each	62.00	534104	964 Euro RS Rear Sway Bar Bushing, 89-94 C2/4. (2) per car.	19.23
521509	964 Euro M030 Rear Springs, 89-94, pair, use with Stock Shocks.	291.00	534111	964 Rear Sway Bar, 89-94 C2/4, 19mm, 4 Adj, Bar/Bushings/Clamps, uses stock links	328.00
521510	Spring Hardware Kit 911 90-98, for Bilstein Cup Shocks with 12mm Shaft 2.25" Spring	152.30	534112	964 Rear Sway Bar Drop Link, 89-94 C2/4, pair	154.00
			542115	964 Rear Wheel Bearing 89-94, 2 per car.	44.50



**ERP 964/993 Shock Monoball**

Replaces the factory rubber mount system with a positive monoball for the upper rear anchor of 964/993's.

964 ... **552509 (2 per car) ... \$207.69 ea.**  
 993 ... **552510 (2 per car) .. \$207.69 ea.**



**MODE 964/993 Shock Monoball**

Replaces the factory rubber mount system with a positive monoball for the upper rear anchor of 964/993's. Can only be used with Bilstein or JRZ Cup style rear shocks.

964 89-90 ..... **552507 ..... \$517.00 kit**  
 964 91-94 ..... **552508 ..... \$581.50 kit**  
 993 95-98 ..... **552510 ..... \$207.69 kit**



**993 Rear Sway Bar Mount Kit**

95-98 for 534201, Cup shocks only.  
**534202 ..... \$239.95 kit**



**ERP 993 Spring Hardware Kit Rear**

993 upper and lower spring perches and lock nuts for Bilstein shocks (2.25 ID springs).

**523610 ..... \$160.00 kit**

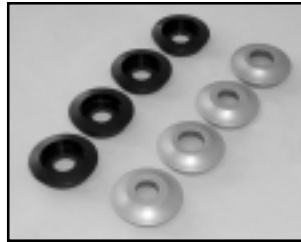

**ERP 993 Solid Mounts for Suspension Carrage**

Solid motor mounts have been used by the factory since the '50's. Greatly increases shifting accuracy and reduces energy losses. Also adds a modest amount of torsional stiffness to the car. All dedicated track cars benefit from these mounts. Need 8

**563013 ..... \$50.00 ea.**



**ERP 993 Monoball Rear**

To ensure that critical suspension settings stay put, these spherical bearings are designed to be direct replacements for the factory rubber bushings...Cary's designs ensure that!

**552511 (8 per car) ..... \$180.30 ea.**



**993 95-98 Bilstein Front and Rear Suspension Kit**

**411159 ..... \$3,077.95 kit**

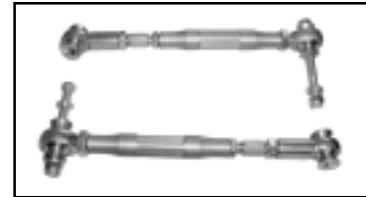

**ERP 993 Rear Toe Steer Link**

As with the kinematic links above, these toe links are easier to use and have a greater range of adjustment. The increased strength is an added benefit. These also can be used with the kinematic links to accurately set bump steer.

**563010 (2 per car) ..... \$316.70 ea.**



**ERP 993 Rear Kinematic Link**

An overly complicated multi-link suspension to start with, these kinematic links were designed to allow exact settings of this complicated link - whose job is to control toe changes during suspension movements. The factory link has a very limited length adjustment with the eccentrics. Between these links and the factory eccentrics, rear toe or bump steer can be set exactly.

**563011 (2 per car) ..... \$291.70 ea.**



**ERP 993 Rear Upper Camber Link**

Departing slightly from the kinematic and toe links above, the main benefit of these camber links is the adjustability of how much camber gain per inch of wheel travel is set. Total adjustability in any suspension system is the only way to get the most out of a suspensions potential.

**563012 (2 per car) ..... \$291.70 ea.**



**993 Euro RS Rear Sway Bar Kit**

95-98, 20mm, 3 adjustments. Bar/Links/Bushings/Brackets, Cup shocks only, needs 534202

**534201 ..... \$749.50 kit**



**ERP 993 GT2 Style (Tilt) ERP Solid Mounts for Suspension Carriage**

Solid mount system for the carriage supports of a 993. These are to the same spec as the GT2 factory EVOII car. This system lowers the front of the carriage allowing the car to have less anti squat and less rear caster (kinematics). The kit allows for the front spacer to be machined of different heights as well. Complete with hardware.  
**563020 ..... \$491.96 kit**

511024	993 Bilstein Rear Shock C2/4/T 95-98 (Right)	241.92	533100	993 Sway Bar Mount Kit Rear for Bilstein Shocks	258.00
511025	993 Bilstein Rear Shock C2/4/T 95-98 (Left)	241.92	534197	993 Rear Sway Bar 20mm, 95-98	161.00
511026	993 Bilstein Rear Shock Sport 95-98 (use with stock springs) 2 per car	242.66	534198	993 Rear Sway Bar Bushing 20mm, 95-98, 2 per car.	18.33
511027	993 Monroe Rear Shock 95-98 OE, left.	159.20	534199	993 Rear Sway Bar Link L/R, 2 per car, 95-98.	59.98
511029	993 Monroe Rear Shock 95-98 OE, right.	159.20	534204	993 ERP Rear Sway Bar 95-98, 1' w/Blades. 1,208.00	
511210	993 Bilstein Cup Rear Shock 95-98	352.61	534206	993 Rear Sway Bar 95-98, 22mm, Cup shock only, 3 adj., needs 534208.	327.00
511220	993 Ohlins Rear Shock Right w/R42 Valving.. 1 per car, 2 way adjustable.	1,157.50	534207	993 Rear Sway Bar 95-98, 19mm, Cup shocks only, needs 534208.	317.00
511221	993 Ohlins Rear Shock Left w/R42 Valving 1 per car, 2 way adjustable.	1,157.50	534208	993 Rear Sway Bar Drop Link Set for 534206 or 534207.	207.00
521508	ERP 964/993 Spring Hat 12mm Hole, 2.25" Spring, each	62.00	534210	993 Rear Sway Bar Kit 95-98 C2, 21mm, 5 Adj.	439.00
521510	Spring Hardware Kit 911 90-98, for Bilstein Cup Shocks with 12mm Shaft 2.25" Spring	152.30	534301	996 Rear Sway Bar, C2 Tip (Coupe, Cabrio, Targa), 18.5mm, 1per car.	112.74
521520	993 Competition Rear Spring 800, see 422182	79.95	534302	996 Rear Sway Bar Bushing, C2 Tip (Coupe, Cabrio, Targa), 2 per car.	5.50
521521	993 GT Rear Spring 1000	79.95	542120	993/996/Turbo '91-on Rear Wheel Bearing, 2 per car	98.52
532110	Shackle for rear ARB (left side)	18.40	563014	Bolt for ERP 993 Rear Suspension Carriage Mounts (563013)	7.79
532120	Shackle for rear ARB (right rear)	18.40	563015	Washer for ERP 993 Rear Suspension Carriage Mounts (563013)	3.19
532130	Bushing cup for ARB (rear)	3.00	563201	993 Euro RS Rear Lower Control Arm 95-98 w/HD Ball Joints (Left)	544.36
533011	SRP ARB Bracket Doubler	15.00	563202	993 Euro RS Rear Lower Control Arm 95-98 w/HD Ball Joints (Right)	544.36
533012	SRP ARB Bracket Nut	3.65			
533014	Mounting console for rear anti-roll bar...Fits 78-89, use Bow Retainer 113.411.333 to use with...	75.97			



**996/Boxster Front/Rear Control Arms with Adjustable Camber**

Designed and built by Fabcar Engineering, these extremely strong and stiff control arms replace the factory aluminum alloy arms that have a short service life and are prone to breaking. These 4130 weldments are stronger and stiffer than the factory arms, plus they allow for easy camber adjusting similar in method to the 956/962 race cars; with a service life in the order of magnitudes longer. Comes complete with a replacement monoball and a 17-4 stainless pin and nylock. These arms have been approved by the ALMS, the American Grand Am and SCCA Speedvision series. Don't take chances with the pressure cast aluminum arms, replace them and rest assured you are buying the strongest and highest quality control arms available. Join the parade to the winner's circle with Fabcar Engineering's legendary quality.

**443100 ..... \$1,130.00 ea.**



**ERP 996 Rear Racing Bump Steer kit**

Kit includes left and right side.

**563060 ..... \$831.00 kit**

511028	996 Bilstein Rear Shock 99- (R or L), 2 per car.	203.76
511232	996 Ohlins Rear Shock Right w/R43 Valving.. 1 per car, 3 way adjustable.	1,125.00
511234	996 Ohlins Rear Shock Left w/R43 Valving.. 1 per car, 3 way adjustable.	1,125.00
521510	Spring Hardware Kit 911 90-98, for Bilstein Cup Shocks with 12mm Shaft 2.25' Spring	152.30
522530	996 Competition Rear Spring 1000, 99-, 2 per car.	79.95
522532	996 GT Rear Spring 1200, 99-, 2 per car.	79.95
522534	996 GT Rear Tender Spring, 99-, 2 per car.	62.66
523100	Rear (Tall) Upper Hat (each)	100.00
532110	Shackle for rear ARB (left side)	18.40
532120	Shackle for rear ARB (right rear)	18.40
532130	Bushing cup for ARB (rear)	3.00
533011	SRP ARB Bracket Doubler	15.00
533012	SRP ARB Bracket Nut	3.65
534301	996 Rear Sway Bar, C2 Tip (Coupe, Cabrio, Targa), 18.5mm, 1per car.	112.74
534302	996 Rear Sway Bar Bushing, C2 Tip (Coupe, Cabrio, Targa), 2 per car.	5.50
534305	996 Rear Sway Bar, C2 6spd (Coupe, Cabrio, Targa), 1 per car.	152.17
534306	996 Rear Sway Bar Bushing, C2 6spd (Coupe, Cabrio, Targa), 2 per car.	12.54
534309	996 Rear Sway Bar, C4/4S, 20.7mm, 1 per car.	132.92
534310	996 Rear Sway Bar Bushing, C4/4S, 2 per car.	8.58
534313	996 GT Rear Sway Bar, 20mm, 4 Adj.	156.25
534314	996 GT Rear Sway Bar Bushing, 2 per car.	14.15
534315	996 GT Rear Sway Bar Drop Link, 2 per car.	279.55
534321	996 GT3 Rear Sway Bar, 20.7mm, 4 Adj, 1 per car.	126.53
534322	996 GT3 Rear Sway Bar Bushing, 2 per car.	7.40
534323	996 GT3 Rear Sway Bar Drop Link, 2 per car.	158.95
534325	996 GT Rear Sway Bar, mm, Adj.	0.00
534326	996 GT Rear Sway Bar Bushing, 2 per car.	0.00
534327	996 GT3R Adjustable Rear Sway Bar Drop Link, 2 per car.	237.60
542096	911 -'68 Rear Wheel Bearing Outer, 2 per car.	26.15
542120	993/996/Turbo '91-on Rear Wheel Bearing, 2 per car	98.52
543110	996 EVO Rear Upright - Right	3,443.50
543111	996 EVO Rear Upright - Left	3,443.50
562130	Nut for Rear Pivot Boxes	1.82
563014	Bolt for ERP 993 Rear Suspension Carriage Mounts (563013)	7.79
563015	Washer for ERP 993 Rear Suspension Carriage Mounts (563013)	3.19
563017	996 ERP Rear A-arm Solid Mount	50.00
563041	996 ERP Rear Adjustable Upper A-arm Link - Long, 99-, 2 or 4 per car, for 10" std length us...	225.00
563042	996 ERP Rear Adjustable Upper A-arm Link - Short, 99-, 2 per car, for rear caster use (2) at ...	225.00
563043	996 ERP Rear Carriage Mount Kit, 99-, 1 per car.	332.30
563051	996 ERP Bump Steer Kit (Toe Steer), 99-, 1 pair per car. ( Can be used with the factory tie rod)	325.00
563052	996 Track Rod, 99-, 2 per car.	69.80
563053	996 Track Rod Nut, 99-, 2 per car.	1.66
563054	996 Track Rod Lock Nut, 99-, 2 per car.	1.13
563055	996 ERP Toe Steer Boot, 2 per car.	30.00
563056	996 ERP Front/Rear Bump Steer End, need 2	193.00
563057	996 ERP Front/Rear Bump Steer End Boot, 2 per car.	30.00