

WEVO . . . The Best 901, 915 & 930 Shifter We Have Ever Used!!!



WEVO Shifter does not come with factory shifter housing

The WEVO Shifter is a precision short shift/spring centered/reverse blocked shift mechanism for 915 equipped 911's. Intended for street cars, club event cars and full competition race cars. This kit can be installed in any version 915 shifter base from cars 1973-1986 (1972 cars can be updated). The WEVO Shifter kit is an alternative to the factory short shift kit. The lever is spring loaded from both sides so will stand in the 3rd - 4th gear plane in neutral. A reverse selection blocker only operates when moving the lever out of 5th gear. The kit will take about 2 hours to install including removal and refitting of the shifter assembly to your chassis. No special tools or skills are required. The installation of a WEVO Shifter will be one of the most positive tactical upgrades you can perform to a Porsche with a 901, 915, or 930 transmission.

- 915 WEVO Shifter Kit Silver **732150** **\$595.00**
- 915 WEVO Shifter Kit Black **732151** **\$595.00**
- 915 WEVO Shifter Kit Classic **732153** **\$595.00**
- 901 WEVO Shifter Classic Only **732155** **\$595.00**
(Fits 911 only)
- 930 WEVO Shifter Black Only **732154** **\$595.00**
- 930 WEVO Shifter Classic **732161** **\$595.00**
- 915 Stock Shifter Boot **732190** **\$22.20**
- WEVO Tall Knob Silver **732152** **\$48.45**
- WEVO Tall Knob Black **732162** **\$48.45**
- WEVO SHIFTER SPRING KIT 3 pairs of alternative lighter springs for your WEVO shifter. Customize the feel, the spring weight, vary it left to right. **732156** **\$37.50**



WEVO . . . G50 SHIFTER

The WEVO G50 shifter is designed for use in the 1987 – 1989 G50 equipped 911 Carrera. This is a short shift unit fashioned after the highly successful WEVO 915 shifter family.

The reduction in lever travel is approximately 30%. The shifter does not have any lateral spring provision as the spring centering is integral with the components inside the G50 transmission. The kit is installed in the stock housing and uses some of the original components. A new shift rod bushing is included as this is a wear item in the original configuration.

The billet lever is available in either black or silver. The WEVO G50 shifter is designed to be installed with the original shift boot and center console. The Prototype units have been tested since January 2004 over 30,000 miles without any issues, rattles or service.

Silver G50 732180 \$595.00
Black G50 732181 \$595.00

Fabcar . . . Racing Shifters are Race Proven.

Models to fit 901, 915, 930, and G50 transmissions.

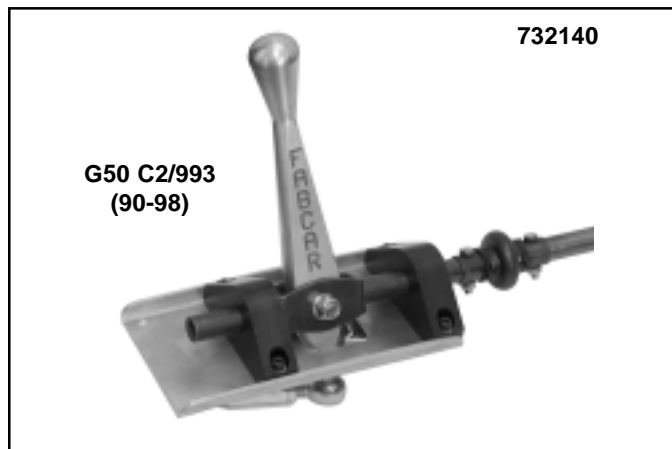

- Short throw
- More convenient for driver (closer to steering wheel)

Fabcar shifter kits

901, 930 **732101** \$1,100.00
 G50 '87-'89 **732130** \$1,700.00
 G50 C2/993 '90-'98 .. **732140** \$1,200.00

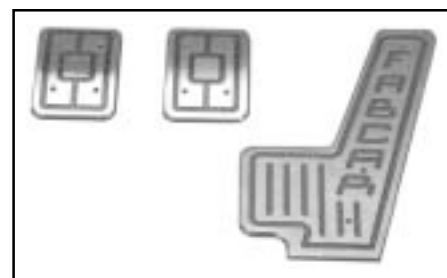

Fabcar Pedal Pads

745100 \$200.00/set



WEVO 915 GateShift kit

The WEVO GateShift kit is an ingenious kit of precision parts that create a gate system inside the 915 transmission. The GateShift kit assists with "hand mapping" of the gear selection pattern and provides positive limits for each gear position. The GateShift kit mimics the operation of the internal gate that offers such an improvement to the G50 series transmissions. The WEVO GateShift kit includes all parts, gaskets and hardware required to install the kit. Designed for all road and race 915 equipped 911's.

332100 \$895.00

WEVO Precision Shift Joints

The WEVO PSJ Family of products are all custom manufactured from an oversize, solid steel "Precision Universal Joint" with hardened steel pins and bores. These products cater for any 911 using 901, 915, or 930 transmissions. The WEVO PSJ's include a durable neoprene boot to protect the mechanism inside the PSJ. The shifter tube side of the PSJ varies with each design.



WEVO Stock Precision Shift Coupler

The WEVO Stock 911 PSJ is a direct bolt-in replacement for the original Porsche shift coupler used in 911's from 1965 to 1986 and 930's from 1975 to 1988.

The WEVO Stock 911 PSJ can be installed and adjusted in minutes.

Replace the sloppy factory coupler at the transmission for a more direct positive feel of your transmission.

Reduce costly missed shifts and over-revs. Can be installed without removing transmission.

733101 \$195.00



WEVO Billet Coupler Clamp

Replace the old and potentially stretched original pressed metal clamp. Super duty billet clamp with all new hardware.

'65-86 911s 733102 \$39.50



WEVO Racing Precision Shift Coupler

Our ultimate version of the PSJ, the original and still the preferred full competition solution.

This joint eliminates the potentially troublesome friction pinch clamp on the rear of the shift tube and replaces it with a 3-bolt flange assembly that eliminates the risk of unintended adjustment.

Length adjustment is accomplished by adding or eliminating 1mm shims between the two bolt flanges (5 shims per kit). You must remove transmission to install and welding is required. Fits '65-86 911s.

733105 \$275.00



WEVO Modular Precision Shift Coupler

The modular PSJ is a product intended for those custom installations where a universal joint might be required in the middle of a shift linkage.

733103 \$125.00



G-50 Carrera Precision Shift Coupler

This product is a direct bolt in replacement for you existing shift tube coupler that is located under the cover plate on the center tunnel near the rear seats. The WEVO G50 Carrera is only suitable for '87 - '89 3.2 liter Carrera and '89 930.

The coupler requires no adjustment and is quick and easy to install.

The WEVO G50 Carrera PSJ does eliminate the O.E. rubber diaphragm coupler that is used as part of the NVH isolation in the stock shifter mechanism - for this reason the level of noise being transmitted into the driver compartment is increased. Many other factors determine the actual increase and drivers seeking to maintain O.E. levels of cabin noise are encouraged to consider this carefully before purchasing or installing the WEVO G50 Carrera PSJ.

The WEVO G50 Carrera PSJ is not suitable for 1989 C4 or any 964 model.

733106 G50 Coupler '87-'89 \$254.00
733107 G50 Coupler 993 \$254.00

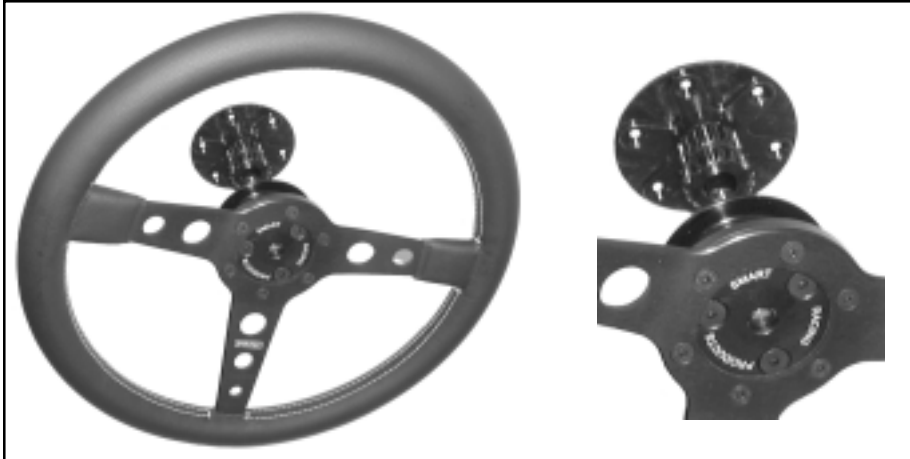

Quick Release Steering Wheel Adapter

This high quality Quick Release fits Momo and Sparco steering wheels. It moves the steering wheel back only 2.2" (3/4" further than our extension) and is simple to install. A great theft deterrent.

Quick Release Assembly (2.2 in. long)..... 722100 \$247.98
 Steering Wheel Extension (1.25 in. long)..... 721100 \$39.95



Steering Wheel Spacer

This high quality spacer fits Momo and Sparco steering wheels. It moves the steering wheel back 1.25" and is simple to install.

Extension (1.25 in. long)
 721100 \$39.95



Quick Release Horn Button Adapter

722200 \$36.80



Momo Steering Wheel Hubs

Hub adapter up to 8/74 911, Carrera, Turbo 722310 \$91.00
 Hub adapter 8/74-on 911, Carrera, Turbo 722320 \$91.00



911 Dead Pedal

RS style foot rest
 745120 \$78.57



915 Robotek Shifter Kit

Make your 915 gearbox feel like a G50. No more 5th to 2nd down-shifts. In neutral, the shift handle will rest in the 3rd and 4th shift gate. This is a must for anyone looking to improve the 915.

732300 \$299.00



Shift Coupler Bushings

Replace original worn out bushings.
 734120 \$11.00

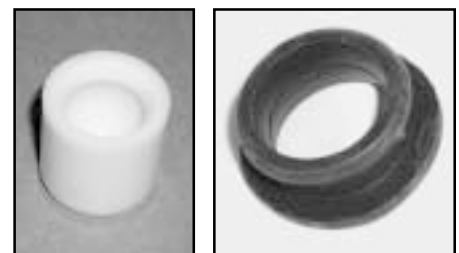

911 Shifter Bushings

911 shifter ball socket
 734100 \$6.66
 911 shift rod bushing
 734110 \$8.98

7 *Hand Levers and Pedal Systems*

711100	Momo Steering Wheel Prototipo, black	218.60
731101	915 RS Shift Knob	110.00
732157	Reverse Lock Out Plunger Replacement	22.38
732158	915/930 Shift Tower 73-86	239.30
732159	Momo Shift Knob Adapter for WEVO shifter	69.30
732160	Shift Boot for WEVO Shifter	124.60
732200	Factory 915 Short Shift Kit	142.77
733104	Tapered Screw for Shift Coupler	3.45
744100	Throttle bell crank bushing at the pedal and on the engine.	2.17
744101	Clutch Bushing	1.42
744102	Brake Pedal Bushing	19.66
744103	Accel Cable Bushing	4.95
745111	AJ 911 Foot Rest '89-98	48.50
745112	AJ 911/930 Foot Rest '65-89 Coupe, left	48.50
745113	AJ 911 Foot Rest '65-89 Targa/Cabrio	48.50